

Specification for 1600 Watts
Switching Power Supply
Model No.: FSH018-7EAG
Marketing PN: R1CA2162B-P7EA
Revision: A1.1

AcBel Polytech Inc.

Prepared by PM	Prepared by EE	Review by ME	Review by EE Leader
Debbie Hung	Yilin Tsai	Eason Kuo	Juxin Hsu

Table of Contents

Table of Contents.....	2
1 Revision Log.....	5
2 Scope.....	6
2.1 Power Supply Overview.....	6
3 AC Input Requirements.....	7
3.1 Input Conditions.....	7
3.2 Input Fuse.....	7
3.3 Harmonic Current and Power Factor Correction.....	7
3.4 Input Connector.....	8
3.5 AC Line Isolation Requirements.....	9
3.6 AC Line Dropout / Hold up time.....	9
3.7 AC Line V_{SB} Hold-up time.....	9
3.8 Inrush Current.....	9
3.9 Efficiency.....	10
3.10 Line Disturbance.....	10
3.11 I_{THD}	11
3.12 Leakage Current.....	11
3.13 AC Line Transient, Compliant with EMC Standard.....	11
3.14 EMI.....	11
3.15 Voltage Interruptions.....	11
3.16 Power Recovery.....	11
4 DC Output Requirements.....	12
4.1 Output Load and Status Regulation.....	12
4.2 Ripple /Noise.....	12
4.3 Dynamic Regulation.....	13
4.4 Audible Noise.....	13
4.5 Immune Voltage.....	13
4.6 Capacitive Loading.....	14
4.7 Turn on/off Overshoot & Undershoot.....	14
4.8 Grounding.....	14
4.9 No Load Condition.....	14
4.10 Close Loop Stability.....	14
4.11 Remote ON/OFF.....	14
4.12 Common Mode Noise.....	15
4.13 Hot Swap Requirement.....	15
4.14 Output Isolation.....	15
4.15 Soft Starting.....	15
4.16 Force Load Share.....	15
4.17 Load Share Signal Characteristics.....	16
4.18 DC Connector and Pin Assignment.....	16
4.19 Handle Retention.....	17
4.20 LED Identification.....	17



5	Protection Requirements	18
5.1	Primary Protection	18
5.2	Secondary Protection	18
5.2.1	Current Limit & Power Protection (OCP & OPP)	18
5.2.2	Over and Under Voltage Protection	18
5.2.3	Short Circuit Protection	19
5.2.4	Reset after Shutdown.....	19
5.2.5	Over Temperature Protection.....	19
6	Signal Requirement	20
6.1	PSON	20
6.2	Power Good (PWOK or P_GOOD)	21
6.3	PRESENT.....	21
6.4	Load Share Signal.....	21
6.5	Sharing Accuracy	22
6.6	SMBAlert.....	22
6.7	AC_FAIL Signal	22
6.8	Address_A0 / A1.....	23
6.9	PMBus CLOCK_SCL & DATA_SDA.....	23
6.10	Smart Redundant Bus	23
6.11	Standby Turn-off.....	23
6.12	Fan Speed Control.....	24
6.13	LED indicators.....	24
6.14	Timing.....	24
7	Additional Requirements	26
7.1	OTP	26
7.2	FAN FAIL.....	26
8	PMBus.....	27
8.1	PMBus requirement.....	27
8.1.1	Accuracy for V_{IN} , I_{IN} , P_{IN} , $12V_{OUT}$, I_{OUT} , P_{OUT}	27
8.1.2	Smart Redundancy	27
8.1.3	Black Box.....	27
8.1.4	System on-Line Bootloader	27
9	Environmental Requirements	28
9.1	Temperature.....	28
9.1.1	Normal Operating Ambient (At Sea Level)	28
9.1.2	Non-Operating Ambient (At Sea Level)	28
9.2	Humidity.....	28
9.2.1	Operating	28
9.2.2	Non-Operating.....	28
9.3	Altitude	28
9.3.1	Operating	28
9.3.2	Non-Operating.....	28
9.4	Thermal shock (none-operating).....	29



ACBEL POLYTECH INC.



ACBEL POLYTECH INC.
康舒科技股份有限公司

159, Sec. 3, Tam-King Rd., Tamsui,
Taipei, Taiwan, 251 R.O.C.
Tel : (02)2623-7904~10 • 2621-7672~9
Sales DID : (02)2623-2750 • 2622-4300
Fax : ☐886-2-2623-6530 • 2623-4156

9.5	Acoustic	29
9.6	Mechanical Shock and Random Vibration	29
10	Reliability	30
10.1	Reliability	30
10.2	E-Cap. Life	30
10.3	Component De-rating	31
11	EMC and Safety Requirements	32
11.1	Safety Mark and Standards	32
11.2	EMI Requirement	32
11.3	Hi-pot.....	32
11.4	Ground Continuity	32
12	Mechanical Drawing.....	33

CONFIDENTIAL DOCUMENT

1 Revision Log

Revision	Description	Approved	Date
A1.0	Initial		20190111
A1.1	Modify 4.18 DC Connector and Pin Assignment A21 B24 short PIN		20190321
A1.1	Modify 9. 5 Acoustic		20190321

CONFIDENTIAL DOCUMENT

2 Scope

This specification establishes the requirements for a custom “1U” form factor, 2000 Watts output, active power factor corrected, and wide-range power supply. Also, the approximate dimensions are 73.5mm (W) x 185mm (D) x 40mm (H). The power supply will be used in 3+1 redundant (load share) and must contain appropriate oring devices on all outputs. The number of PSU would be limited to two.

2.1 Power Supply Overview

Application	Sever System	
AC Input & DC input	100-240V _{AC} , 240V _{DC}	
Power Factor Correction	Active	
Output Power	1600 Watts maximum continuous	
EMC Classification	EN61000-4-5 2KV common mode, 1KV Differential mode	
Outputs	12V Main Output (12V _{OUT})	12V Standby (V _{SB})
Nominal Output Voltage	12.20 V	12.00 V
Voltage Regulation	± 5%	± 5%
Minimum Operating Current	0.1 A	0.1 A
Maximum Operating Current	133 A	3 A

3 AC Input Requirements

3.1 Input Conditions

AC input Parameter	Minimum	Nominal	Maximum	Unit
Low Line V_{IN}	90	100-127	140	$V_{AC,RMS}$
High Line V_{IN}	180	200-240	264	$V_{AC,RMS}$
Frequency f_{AC}	47	50/60	63	Hz
I_{IN}			10A (High Line) 12A (Low Line)	$A_{AC,RMS}$
V_{BROWN_IN}	81	85	89	$V_{AC,RMS}$
V_{BROWN_OUT}	70	75	80	$V_{AC,RMS}$
V_{IN_OVP}	300			$V_{AC,RMS}$

DC input Parameter	Minimum	Nominal	Maximum	Unit
V_{IN}	180	240	300	V_{DC}
I_{IN}			10A ($_{240Vdc}$)	A_{DC}
V_{BROWN_IN}	166	170	175	V_{DC}
V_{BROWN_OUT}	156	160	165	V_{DC}
V_{IN_OVP}	310			V_{DC}

Note 1. Due to the C14 Inlet current limit, max Brown-in / Brown-Out loading should operate 80% of rated load.
 2. The I_{in} is specified when the V_{in} at nominal condition

3.2 Input Fuse

A normal-fast-blow fuse must be placed in the single line fuse on the line/hot wire of the AC input. AC inrush does not cause the ac line fuse to blow under any condition. All protection circuits in the power supply do not cause the ac fuse to blow unless a component in the power supply has failed.

3.3 Harmonic Current and Power Factor Correction

The power supply shall incorporate universal power input with active power factor corrections, which shall reduce line harmonics in accordance with the EN61000-3-2 and JEIDA MITI standards.

The power factor lists as below:

Load	10%	20%	50%	100%
P.F.-MIN	0.91	0.97	0.98	0.99

Tested at 230VAC & 240 VAC / 50Hz & 60Hz, 115VAC / 60Hz, measurement environment shall comply with 80+ or energy star regulation, and take the worst result from one of both.

3.4 Input Connector

The AC input receptacle shall be an IEC-320 type C14 capable of at least 15A at 120V_{AC} rating and 10A at 240V_{AC} rating. This connector is located at the frond side of power supply. There is a retainer to fix the line cord to avoid accident disconnection.

CONFIDENTIAL DOCUMENT

3.5 AC Line Isolation Requirements

The power supply shall meet all safety agency requirements for dielectric strength. Additionally, power supply vendor must provide Intel with written confirmation of dielectric withstand test which includes: voltage level, duration of test and identification detailing how each power supply is marked to indicate dielectric withstand test had been completed successfully. Transformers' isolation between primary and secondary windings must comply with the 3000V_{AC} (4242V_{DC}) dielectric strength criteria. If the working voltage between primary and secondary dictates a higher dielectric strength test voltage the highest test voltage should be used. In addition the insulation system must comply with reinforced insulation per safety standard IEC 950. Separation between the primary and secondary circuits, and primary to ground circuits, must comply with the IEC 950 spacing requirements.

3.6 AC Line Dropout / Hold up time

An AC line dropout is defined to be when the AC input drops to 0V_{AC} at any phase of the AC line for any length of time. During an AC dropout the power supply must meet dynamic voltage regulation requirements. An AC line dropout of any duration shall not cause tripping of control signals or protection circuits. If the AC dropout lasts longer than the holdup time the power supply should recover and meet all turn on requirements. The power supply shall meet the AC dropout requirement over rated AC voltages and frequencies. A dropout of the AC line for any duration shall not cause damage to the power supply.

Loading during AC dropout / holdup	Holdup time / Dropout duration
75% of rated load	10 mSec

3.7 AC Line V_{SB} Hold-up time

The V_{SB} output voltage should stay in regulation under its full load (static or dynamic) during an AC dropout of 70 mSec min (= V_{SB} holdup time) whether the power supply is in ON or OFF state (PSON asserted or de-asserted).

3.8 Inrush Current

The power supply shall provide circuitry to limit the turn-on inrush current on any initial current surge or spike of 10ms or less will not exceed 30A peak, which called as first inrush current. Any additional inrush current surges or spikes in the form of AC cycles or multiple AC cycles greater than 10mSec, and less than 500 m Sec, must not exceed 25A peak, which called as second inrush current. After 1.2 Sec the AC input current must meet the requirements in section 3.1 & 8.1.

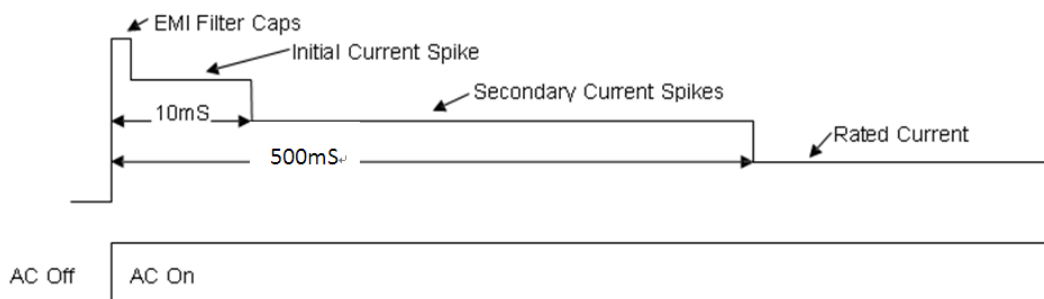

Notes:

1. The inrush current due to the EMI filter capacitors can be ignored.
2. All internal components (including the fuse, bulk rectifiers and surge limiting device) must be able to withstand the surge current without damage the power supply.
3. The inrush limiting circuitry shall be designed such that if the active bypass circuitry is not functional the remaining circuitry shall not cause any smoke/flame potential safety issue.
4. The inrush current must meet at cold / warm start.
5. For the time less than line drop output, the inrush current may exceed than 30A, the I2T of input current at this condition shall be less than I2T of first inrush current
6. For the repetitive ON/OFF inrush current performance, the minimize period is 10 sec, the AC available duty is 30% of 10sec.

3.9 Efficiency

The Power supply shall meet 80plus Platinum efficiency requirement at 230V_{AC}, the measurement and validation shall complete follow 80 plus regulation.

Loading	10% of max Load	20% of max Load	50% of max Load	100% of max Load
Efficiency _{MIN}	82%	90%	94%	91%

Note:

1. Fan loading is not included for efficiency measurements. Efficiency to be measured at 20-25°C after supply has run for 30 minutes.
2. The power supply shall pass all efficiency measurements by 0.2% to guarantee design margins for production.

3.10 Line Disturbance

Line disturbance shall be defined as “sag” and “surge” conditions. “Sag” conditions are also commonly referred to as “brownout”, these conditions will be defined as the AC line voltage dropping below nominal voltage conditions. “Surge” will be defined to refer to conditions when the AC line voltage rises above nominal voltage.

The power supply shall meet the requirements under the following AC line sag and surge conditions.

Item	Sag	Input Voltage	Input Frequency	Performance Criteria
0 - 1/2 cycle ^{note 1}	95%	Nominal AC Voltage Ranges	50 / 60 Hz	No loss of function or performance
> 1 AC cycle	> 30%	Nominal AC voltage Ranges	50 / 60 Hz	Loss of function acceptable, self-recoverable.

Item	Surge	Input Voltage	Input Frequency	Performance Criteria
Continuous	10%	Nominal AC voltage Ranges	50 / 60Hz	No loss of function or performance
0 - 1/2 cycle ^{note 1}	30%	Nominal AC voltage Ranges	50 / 60Hz	No loss of function or performance

Note:

1. During 0-1/2 cycle test condition as above, the load should be set to 75% maximum (follow holdup time requirement) and minimum load.
2. When test condition included high line to low line range, Maximum Load should be the rated current of the lower voltage range. If the output current larger than rated current of the lower voltage range, power supply may latch off due to output over current protection.

3.11 I_{THD}

This test shall be measured at 115V_{AC} & 230V_{AC} / 50Hz & 60Hz

Load	10%	20%	50%	100%
$I_{THD, MAX}$	20%	10%	8%	5%

3.12 Leakage Current

Maximum input leakage current at 264 V_{AC}, 60Hz, shall not exceed 0.875 mA.

3.13 AC Line Transient, Compliant with EMC Standard

Power supply shall operate within specifications under the followings conditions:

- a) Transients as defined in IEC61000-4-4, Electrical Fast Transients standard, up to 1 KV at AC line.
- b) Transients as defined in IEC61000-4-5, Electrical Surge standard.
Common mode 2.0 KV
Differential mode 1.0 KV
- c) Power supply shall comply with IEC61000-4-2, Electrostatic Discharge standard, up to 8 KV with contact 15 KV with air discharge.
- d) Power supply shall meet all the transient requirements for the CE mark designation.

3.14 EMI

The power supply shall comply with FCC and EN55022 (CISPR22) Class A for conducted and radiated emissions. It must comply at 100 - 120, 200 - 240VAC / 50Hz with 6dB margin as minimum.

3.15 Voltage Interruptions

The power supply shall comply with the limits defined in EN55024: 1998/A1: 2001/A2: 2003 using the IEC 61000-4-11: Second Edition: 2004-03 test standard and performance criteria_C defined in Annex B of CISPR 24.

Performance criteria C, Temporary loss of function is allowed provided the function is self-recoverable or can be restored by the operation of the controls.

3.16 Power Recovery

The power supply shall recover automatically after an AC power failure. AC power failure is defined to be any loss of AC power that exceeds the dropout criteria. (follow 3.10)

4 DC Output Requirements

4.1 Output Load and Status Regulation

The following table provides a summary of specifications for each individual output.

The output voltage must meet the below table and the V_{SB} output shall be present when an AC input greater than the power supply turn on voltage is applied.

Parameter	V_{in} Rating	Power Rating (W)	Min Current (A)	Max Current Rating (A)	Voltage Regulation
12V main (90-140V _{AC})	115 V _{AC}	996	0.1	83	12.20V +/-5%
12V main (180-264V _{AC})	230 V _{AC}	1596	0.1	133	
12Vsb	--	36	0.1	3	12.00V +/-5%

Note: 1. With two power supplies in parallel, the power supplies must support 1600W at high line AC voltage range.

4.2 Ripple /Noise

The following output ripple/noise requirements will be met throughout the load ranges specified in section 4.1 and under all input voltage conditions specified in section 3.1 and temperature condition specified in section 9.1.

Outputs	Maximum	Capacitive Load
V_{SB}	120 mV _{PK-PK}	Min. Cap Load
12V _{OUT}	120 mV _{PK-PK}	

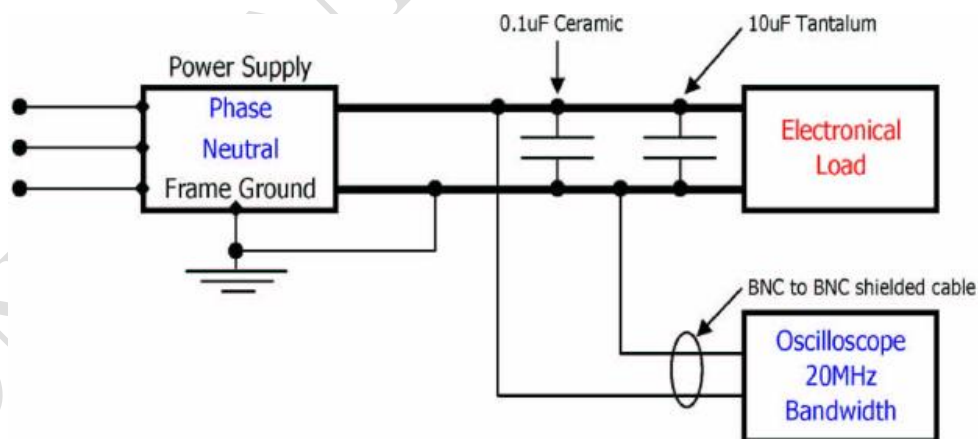

Notes:

1. Output ripple & noise should be measured at the pins of the mating output connector.
2. Connect the probe with the input tip and ground as short as possible.
3. Output ripple & noise measured with only PSU capacitance plus 10 uF Tantalum and 0.1uF Ceramic capacitor.
4. Ripple & noise are defined as periodic or random signals over the frequency band of 10 Hz to 20 MHz.

4.3 Dynamic Regulation

The output voltage shall remain within the limits specification in section 4.1 Voltage Regulation for the step loading and within the limit specification in below table for the capacitive loading. The load transient repetition rate shall be tested between 50 Hz and 10 kHz at duty cycles ranging from 10% - 90%.

The load transient repetition rate is only a test specification. The step load may occur anywhere within the Min Load 1A to the Max Load show in below table. During 12V_{OUT} output load changes from minimum to maximum or maximum to minimum, the power supply must not shutdown.

Outputs ¹	Step Load Size	Slew Rate	Test Capacitor load
12V _{OUT}	60%	0.5 A/uS	2000 uF
V _{SB}	50%	0.5 A/uS	20 uF

4.4 Audible Noise

No abnormal audible noise is allowed to be generated by the power supply.

4.5 Immune Voltage

The PSU should be immune to any residual voltage placed on its outputs (typically a leakage voltage through the system from standby output) up to 500 mV. There shall be no additional heat generated, nor stressing of any internal components with this voltage applied to any individual or all outputs simultaneously. It also should not trip the protection circuits during turn on.

The residual voltage at the power supply outputs for no load condition shall not exceed 100 mV when AC voltage is applied and the PSON# signal is de-asserted.

4.6 Capacitive Loading

The PSU will be able to power up and operate normally with the capacitive load on the DC outputs, the power supply shall be stable and meet all requirements with the following capacitive loadings.

Outputs	MIN	MAX	Units
V_{SB}	20	3,100	uF
12V _{OUT}	1000	25000	uF

4.7 Turn on/off Overshoot & Undershoot

During the turn-on or turn-off stage, the output voltage including the standby output, under any of the conditions specified in section 4.1 and temperature section 9.1, capacitive loading section 4.6 will less than 10% above the nominal voltage and will settle into the regulation band within 20 mSec.

The output voltage undershoot during turn-off of any of the output, including the Standby output, under any of the condition specified in section 4.1 and temperature section 9.1, capacitive loading section 4.6 shall not exceed than 1.0V.

There must be a smooth and continuous ramp of each output voltage from 10% to 95% of its final set point within the regulation band. No voltage of opposite direction will be present on any output during turn-on or turn-off stage.

4.8 Grounding

The output ground of the pins of the power supply provides the output power return path. The output connector ground pins shall be connected to the safety ground (power supply enclosure). This grounding should be well designed to ensure passing the max allowed Common Mode Noise levels.

4.9 No Load Condition

This condition shall not trip any failure circuitry shutdown or cause any permanently damaged to the power supply. Also, the power supply shall normal operate when the power supply is turn on or when the power supply is already on at no load condition.

When the power supply is subsequently loaded, it must begin to regulate and source current without fault.

4.10 Close Loop Stability

The power supply shall be unconditionally stable under all line/load/transient load condition including capacitive load. A minimum of 45 degrees phase margin and -10dB gain margin is required.

The power supply manufacturer shall provide proof of the unit's closed-loop stability with local sensing through the submission of Bode plots.

Bode Plot documentation will have Phase and Gain margin data, line and load conditions, as well as the oscillator injection level. For verification purposes the plots will have the method of test and injection points clearly documented on a current schematic. Stability plots need to be provided at both the upper and lower operating temperature limits.

4.11 Remote ON/OFF

Differential (Single ended) remote sense is to be provided for the designated remote sense outputs. The remote sense must be able to compensate for the defined system output voltage drop over the system output resistance (after the output connector).

The remote sense lines must be protected such that if only the remote sense is connected to the load, or there is a short across the remote sense, the power supply is not damaged.

4.12 Common Mode Noise

The Common Mode Noise on any output shall not exceed 350 mV_{PK-PK} over the frequency band of 10 Hz to 20 MHz.

1. The measurement shall be made across a 100 Ω resistor between each of DC outputs, including ground at the DC power connector and chassis ground (power subsystem enclosure).
2. The test set-up shall use a FET probe such as Tektronix model P6046 or equivalent

4.13 Hot Swap Requirement

Hot swapping a power supply is the process of inserting and extracting a power supply from an operating system. During this process, the output voltage shall remain within the regulation limits specified in section 4.1 with capacitive load specified in section 4.6. The hot swap test must be conducted when the system is operating under static, dynamic condition and zero loading condition.

The power supply should use a latching mechanism to prevent insertion and extraction of the power supply when AC power cord is inserted into the power supply.

4.14 Output Isolation

All outputs have an isolating device to isolate the power supply from the system power during a power supply failure or during a hot swap operation. This device is located in power supply. This device is an oring diode or functional equivalent.

4.15 Soft Starting

The Power Supply shall contain control circuit which provides monotonic soft start for its outputs without overstress of the AC line or any power supply components at any specified AC line or load conditions.

4.16 Force Load Share

The 12V main will have active load sharing. The output will share within +/-5% at 50%-100% load, +/-10% at 20-50% load. The failure of a power supply should not affect the load sharing or output voltages of the other supplies still operating and does not cause these outputs to go out of regulation in the system. The power supplies must be able to load share with up to 2 power supplies in parallel.

The V_{SB} standby output is passive sharing. The V_{SB} of power supplies are connected together in the system, so that a failure or hot swap of a redundant power supply does not cause these outputs to go output of regulation in the system.

4.17 Load Share Signal Characteristics

The load share signal is only for the load function. The load share signal characteristics are defined as below table.

Item	Description	Min	Nominal	Max
$V_{SHARE}; I_{OUT} = \text{Max}$	Voltage of load share bus at specified maximum output current	7.76 V	8.0 V	8.24 V
$\Delta V_{SHARE} / \Delta I_{OUT}; I_{OUT} > 1A$	Slope of load share bus voltage with changing load		$8.00 / I_{MAX}$ V/A	
I_{SHARE} sink; $V_{SHARE} = 4.00V$	Amount of current the load share bus output from each power supply sources.			0.5 mA
I_{SHARE} source $V_{SHARE} = 4.00V$	Amount of current the load share bus output from each power supply sinks.	4 mA		

4.18 DC Connector and Pin Assignment

Pin No.	Pin Name	Pin Type	Pin Length	Description
A1~A9 B1~B9	GND	12VOUT main & VSB Return	Long	12VOUT main & VSB Return
A10~A18 B10~B18	12VOUT	12VOUT main output	Standard	12VOUT main output
A19	SDA	I / O	Short	SMBus / PMBus Data
A20	SCL	I / O	Short	SMBus / PMBus Clock
A21	PSON	Input	Short	Active low; 12VOUT main output on/off control
A22	SMBAlert	Output	Short	Active high; I2C alert signal (interrupt)
A23	RETURN Sense	Analog Input	Standard	12VOUT main output Remote Sense -
A24	12VOUT Remote Sense	Analog Input	Standard	12VOUT main output remote sense +
A25	PWOK	Output	Standard	Active high; indicate 12VOUT main is valid
B19	A0	Input	Standard	PMBus address 0
B20	A1	Input	Standard	PMBus address 1
B21	12V Standby VSB	Aux Power	Standard	Standby voltage
B22	Smart Redundant Bus	I / O	Standard	Cold Redundancy Bus 1
B23	12VOUT Load Share Bus	Analog Output	Standard	12VOUT main output load current sharing
B24	Present	Input	Short	Power Supply Present
B25	AC fail	Output	Standard	Active low; Detect AC Power

Pin length definition is illustrated on below:

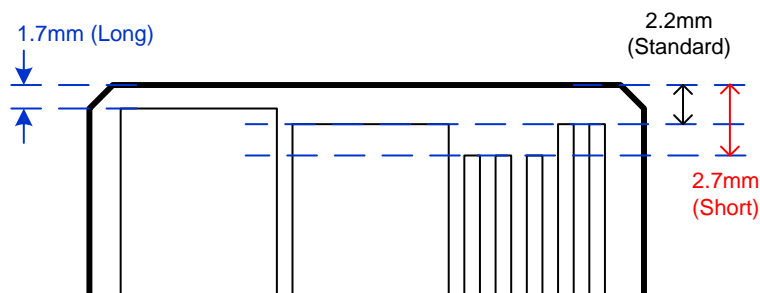

4.19 Handle Retention

The power supply shall have a handle to assist extraction. The module shall be able to be inserted and extracted without the assistance of tools. The power supply shall have a latch which retains the power supply into the system and prevents the power supply from being inserted or extracted from the system when the AC power cord is pulled into the power supply.

The handle shall protect the operator from any burn hazard and be designed plastic handle or equivalent material.

4.20 LED Identification

The power supply shall use a bi-color LED; Amber [λ : 607-613 nm] & Green [λ : 562-568 nm]. Both LEDs luminance density is designed for 5 mcd.

CONFIDENTIAL DOCUMENT

5 Protection Requirements

5.1 Primary Protection

The supply must have internal primary over current protection. A normal blow (fast blow), high-breaking-capacity fuse must be placed in the line side of the input circuit. This fuse is not to be considered replaceable for purposes of determining power supply reliability and life as specified in Section 10.

If any component on the line side of the fuse is shorted or opened, it shall not cause a fire or any other safety risk.

5.2 Secondary Protection

5.2.1 Current Limit & Power Protection (OCP & OPP)

The power supply shall have current limit to prevent the outputs from exceeding the values shown in table below. When the current limit is in OCP1, OCP2 or OCW2 status, the power supply shall shutdown and retry eight times to recover, and if the status still occurred that shall latch off. The latch will be cleared by an AC power interruption or PS_ON cycle on/off. The power supply shall not be damaged from repeated power cycling in this condition. V_{SB} will be auto-recovered after removing OCP limit.

Outputs	Status	Output Current Range		Minimum Keep time	SMBAlert	SMBAlert Mode
		Minimum	Maximum			
+12VSB	OCP	3.5 A	4.5 A	-	-	-
+12V (High line)	OC Warning1	145 A	155 A	continuous	10~30ms	1. SMBAlert will be asserted within asserting time. Afterward, SMBAlert is latched for 100ms and will be reset by PSU itself in OC Warning status.
	OCP1	155 A	165 A	50ms	-	
	OC Warning2	170 A	185 A	50ms	<20us	
	OPP/OCP2	185 A	210 A	500us	-	
+12V (Low line)	OC Warning	89 A	93 A	continuous	10~30ms	2. If power shut down, SMBAlert will keep latching until AC power cycle on/off or PS_ON cycle on/off.
	OCP1	93 A	101 A	50ms	-	
	OC Warning2	101 A	119 A	50ms	<20us	
	OPP/OCP2	119 A	125 A	500us	-	

Note: Power supply may shut down in OC Warning1 status if OTP occurred.

5.2.2 Over and Under Voltage Protection

When the power supply is in $12V_{OUT}$ OVP or UVP status, the power supply shall shutdown and retry eight times to recover, and if the status still occurred that shall latch off.



Outputs	Under Voltage		Over Voltage		Unit
	Minimum	Maximum	Minimum	Maximum	
V _{SB}	10	11	14	14.7	V
12V _{OUT}	10	11	14	14.7	V

Notes:

1. The above OV/UV test will be satisfied throughout AC input in section 3.1 and the entire operating temperature range in section 9.1
2. Standby output shall not latch off due to an under/over voltage condition.
3. A fault on any output other than Standby will not cause the Standby to turn off. Also, that fault on Standby will cause the other outputs to turn off but not latch off.
4. The power supply will provide latch mode except for Standby output.

5.2.3 Short Circuit Protection

A short circuit is considered to be resistance of 40m ohms or less, applied to any output during start-up or while running will not cause any damage to the power supply (connectors, components, PCB traces, etc.).The power supply shuts down and latches off for short on main outputs but recovers upon PS_ON assertion or AC toggle

When the Standby output V_{SB} is shorted the output, all outputs shuts down upon a short circuit of the V_{SB}. When the short is removed on V_{SB}, the power supply shall recover automatically.

5.2.4 Reset after Shutdown

If the power supply latches into a shutdown state due to a fault condition on any output, the power supply will return to normal operation only after the fault has been removed and the power supply has been power- cycled. Both methods of resetting the power supply shall be designed into the supply so that the user may choose which method to use.

Reset can be accomplished in one of two ways as below:

- a) Removing AC input power, waiting for Standby output to drop below 1.0V, then reapplying AC power. The time it takes for Standby output to drop below 1.0V shall not exceed 15 seconds.
- b) Cycling the state of PSON from on to off to on. The minimum cycle time will be 100 mSec.

5.2.5 Over Temperature Protection

The power supply will be protected against over temperature conditions caused by loss of fan cooling or excessive ambient temperature. In an OTP condition the PSU will shut down. When the power supply temperature drops to within specified limits, the power supply shall restore power automatically.

The OTP circuit must have built in hysteresis such that the power supply will not oscillate on and off due to temperature recovering condition. The OTP trip level shall have a minimum of 4 °C of ambient temperature hysteresis.

Ambient temperature	TYPICAL
Over Temp. warning (OTW)	62°C ± 3°C
Over Temp. Protection (OTP)	66°C ± 3°C

Notes:

1. When the power supply operates above 90% load, components hot spot OTP may occurred first.

6 Signal Requirement

This requirement shall be met throughout the load regulation condition specified in section 4.1, under all input voltage condition specified in section 3.1 and temperature condition specified in section 9.1.

6.1 PSON

The PSON signal is required to remotely turn on/off the power supply. PSON is an active low signal that turn on the main power rails. When this signal is not pulled low by the system, or left open, the outputs turn off.

The power supply shall provide an internal pull-up to high. The power supply shall also provide de-bounce circuitry on PSON to prevent it from oscillating On/Off at startup when activated by mechanical switch.

PSON signal should be logic level low (PSU ON) when the voltage between 0V ~ 0.66V, and logic level high (PSU OFF) when the voltage between 2.64V ~ 3.46V.

Signal type	Accepts an open collector/drain input from the system Pull-up to internal 3.3V located in power supply	
PSON =Low	PSU ON	
PSON = Open or High	PSU OFF	
	MIN	MAX
Logic level low (PSU ON)	0 V	0.66 V
Logic level high (PSU OFF)	2.64 V	3.46 V
Source current, $V_{PSON} = \text{low}$		4 mA
Power up delay: $T_{PSON_ON_DELAY}$	5 mSec	400 mSec
Power off delay: T_{PSON_PWOK}		5 mSec

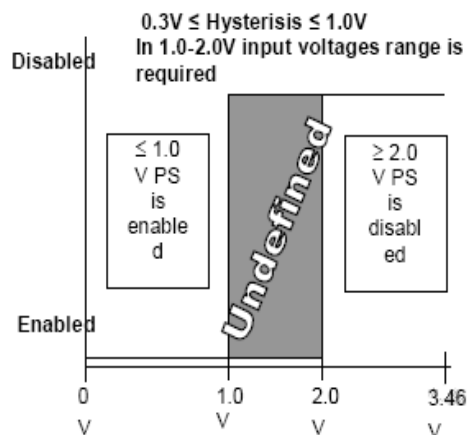



ACBEL POLYTECH INC.



ACBEL POLYTECH INC.
康舒科技股份有限公司

159, Sec. 3, Tam-King Rd., Tamsui,
Taipei, Taiwan, 251 R.O.C.
Tel : (02)2623-7904~10 • 2621-7672~9
Sales DID : (02)2623-2750 • 2622-4300
Fax : ☐886-2-2623-6530 • 2623-4156

6.2 Power Good (PWOK or P_GOOD)

This signal should be asserted high by the power supply to indicate that all outputs are within the regulation thresholds listed in section 4.1. Conversely, this signal should be de-asserted to a low state when any of the DC outputs voltage falls below its under voltage threshold, or when mains power has been removed for a time sufficiently long so that power supply operation can't be guaranteed.

This signal must be driven low at least 1ms before any of the outputs go out of regulation. Also, that will be defined and selected for inclusion from any variation of the following three items:

A.) AC Power Loss ; B.) Fan Failure ; C) Over Temperature

Signal type	Open collector / drain output from power supply. Pull-up to 3.3 V located in system	
PWOK or P_Good = High	DC Outputs O.K.	
PWOK or P_Good = Low	DC Outputs N.G.	
	Minimum	Maximum
Logical Level Low, $I_{SINK} = 400 \mu A$	0 V	0.4V
Logical Level High, $I_{SOURCE} = 200 \mu A$	2.4V	3.46V
Sink current, PWOK = low		400 μA
Source current, PWOK = high		2 mA
PWOK delay: T_{PWOK_ON}	100 mSec	500 mSec
Power down delay: T_{PWOK_OFF}	1 mSec	
PWOK or P_Good Fall Time		100 μSec

6.3 PRESENT

This pin will be tied to Standby return through a 0 ohms resistor. System side should have a pull-up resistor which limits the max current 4mA to go through from this signal pin to the power supply.

6.4 Load Share Signal

This input / output will allow two power supplies to share output current between them.

If one of the supplies fails the remaining supplies must pick up the entire load without any of the outputs dropping out of regulation. A defective supply that is connected to the output voltage bus will not have adverse effect on the operation of the remaining function supplies.

Total Load	Number of supplies	V_{LS} (V) Minimum	V_{LS} (V) Nominal	V_{LS} (V) Maximum
100%	2	3.85	4	4.15
50%	2	1.8	2	2.2
20%	2	0.64	0.8	0.96
100%	1	7.76	8	8.24
50%	1	3.8	4	4.2
20%	1	1.4	1.6	1.8
0%	1	0	0	0.3



ACBEL POLYTECH INC.



ACBEL POLYTECH INC.
康舒科技股份有限公司

159, Sec. 3, Tam-King Rd., Tamsui,
Taipei, Taiwan, 251 R.O.C.
Tel : (02)2623-7904~10 • 2621-7672~9
Sales DID : (02)2623-2750 • 2622-4300
Fax : ☐886-2-2623-6530 • 2623-4156

6.5 Sharing Accuracy

12V_{OUT} output should share load tolerance the average output current from full load to 20% load.

Load	Sharing Accuracy
50 - 100%	±5%
20 - 50%	±10%

Note 1: Sharing accuracy is not measured under transient conditions, but under transient conditions a false over current fault must not occur.

2: Current sharing is not required power on of the outputs until the PWOK signal is asserted. (All outputs are valid)

6.6 SMBAlert

This signal indicates that the power supply is experiencing a problem that the user should investigate. This shall be asserted due to Critical events or Warning events. The signal shall activate in the case of critical component temperature reached a warning threshold, general failure, over-current, over-voltage, under-voltage, failed fan. This signal may also indicate the power supply is reaching its end of life or is operating in an environment exceeding the specified limits.

Signal type	Open collector / drain output from power supply. Pull-up to 3.3 V located in system	
SMBAlert = High	OK	
SMBAlert = low	Power Alert to system	
	Minimum	Maximum
Logical Level Low, I _{SINK} = 4 mA	0 V	0.4 V
Logical Level High, I _{SINK} = 50 uA	2.0 V	3.46 V
Sink current, Alert#=low		4 mA
Sink current, Alert# = high		50 uA
Alert# rise and fall time		100uSec

6.7 AC_FAIL Signal

This signal indicates that the power supply detects input voltage. This shall be asserted due to input voltage as 3.1. The signal shall activate brown out voltage.

Signal type	Open collector / drain output from power supply. Pull-up to 3.3 V located in system	
SMBAlert = High	Line voltage Failure	
SMBAlert = low	Line voltage ok	
	Minimum	Maximum
Logical Level Low, I _{SINK} = 4 mA	0 V	0.4 V
Logical Level High, I _{SINK} = 50 uA	2.0 V	3.46 V
Sink current, Alert#=low		4 mA
Sink current, Alert# = high		50 uA
Alert# rise and fall time		100uSec



ACBEL POLYTECH INC.



ACBEL POLYTECH INC.
康舒科技股份有限公司

159, Sec. 3, Tam-King Rd., Tamsui,
Taipei, Taiwan, 251 R.O.C.
Tel : (02)2623-7904~10 • 2621-7672~9
Sales DID : (02)2623-2750 • 2622-4300
Fax : ☐886-2-2623-6530 • 2623-4156

6.8 Address_A0 / A1

This signal is defined by end user system for PMBus communication, to allocate address of power supply unit in particular slot location

Signal type	Input pin, Pull-up to internal 3.3V located in power supply	
Adress_A0/A1 = high	Address 1	
Adress_A0/A1 = low	Address 0	
	Minimum	Maximum
Logical Level Low	0 V	0.4 V
Logical Level High	2.0 V	3.57 V

6.9 PMBus CLOCK_SCL & DATA_SDA

SCL is the SMBus clock input to the supply, SDA is the bi-directional SMBus data path to /from the supply. Both have a pull-up resistor to 3.3 V internal located in power supply. The week pull-up must be diode isolated to prevent an unpowered/ faulted supply from loading the signal. It must be designed to not glitch bus during hot plug and unplugging.

The main pull-up resistors are provided by the system and may be connected to 3.3V or 5V.

The PMBus operation frequency is 100 kHz.

It shall conform to SMBus V2.0 signaling protocol standards. And this specification is based on the PMBus specification parts I and II, revision 1.2.

Note:

All I²C devices will be powered from the outside of the standby Oring-device. This will allow the status to be read from a supply that is not powered on, or has some other fault.

Some types of protection must be provided so a fault within the supply does not take down the bus.

6.10 Smart Redundant Bus

This signal should be connected together at system board for smart redundant function. Please refer to the PMBus specification for detail.

6.11 Standby Turn-off

Following removal of AC power, the Standby output will remain at its steady state value until such time as it begins to decrease in voltage. The decrease will be monotonic in nature dropping to 0.5 V or less. There will be no other perturbations of this voltage at, or following, removal of AC power.

6.12 Fan Speed Control

The power supply shall incorporate a 40 x28 mm fan for cooling the power supply when installed in the system. The airflow direction shall be from the card edge connector side to the AC inlet side of the power supply. The Fan speed control must have close loop algorithm based on both the critical component temperature and the ambient temperature. Thus ensure the PSU Fan will always ramp to maximum speed under any condition to protect the power supply from overheating. These conditions include high ambient temperatures; loading, AC input, and airflow impedance.

After the new load and/or cooling condition steady state is established, transition to the steady state fan speed shall take place within 60 Sec.

6.13 LED indicators

The power supply may have a single Bi-color (Green-Amber) Configuration.

Power Supply Condition	LED State
Output ON and OK	GREEN
No AC power to all power supplies	AMBER Then OFF
AC present / Only V_{SB} on (PS off) or PS in Smart redundant state / Off line mode	1 Hz Blink GREEN
AC cord unplugged or AC power lost; with a second power supply in parallel still with AC input power.	AMBER
Power supply warning events where the power supply continues to operate; high temp, high power, high current, slow fan, UV.	GREEN
Power supply critical event causing a shutdown; failure, OCP, OVP, Fan Fail	AMBER
Power supply FW updating	1 Hz Blink GREEN

6.14 Timing

These are the timing requirements for the power supply operation. All outputs must rise monotonically. Table below shows the timing requirements for the power supply being turned on and off via the AC input, with PSON held low and the PSON signal, with the AC input applied.

ITEM	DESCRIPTION	MIN	MAX	UNITS
T_{VSB_RISE}	Standby voltage rise time for V_{SB}	1	25	mSec
T_{12VOUT_RISE}	Output voltage rise time for 12V _{OUT}	5	70	mSec
T_{VSB_ON_DELAY}	Delay from AC being applied to 12V _{SB} being within regulation.	--	1500	mSec
T_{AC_ON_DELAY}	Delay from AC being applied to 12V _{OUT} output voltage being within regulation.	--	3000	mSec
T_{12VOUT_HOLDUP}	Time 12V _{OUT} output voltage stay within regulation after loss of AC with 75% load.	11	--	mSec
T_{PWOK_HOLDUP}	Delay from loss of AC to de-assertion of PWOK with 75% load.	10	--	mSec
T_{PSON_ON_DELAY}	Delay from PSON# active to output voltages within regulation limits.	5	400	mSec



ACBEL POLYTECH INC.



ACBEL POLYTECH INC.
康舒科技股份有限公司

159, Sec. 3, Tam-King Rd., Tamsui,
Taipei, Taiwan, 251 R.O.C.
Tel : (02)2623-7904~10 • 2621-7672~9
Sales DID : (02)2623-2750 • 2622-4300
Fax : ☐886-2-2623-6530 • 2623-4156

T_{PSON_PWOK}	Delay from PSON# deactivate to PWOK being de-asserted.	--	5	mSec
T_{PWOK_ON}	Delay from output voltages within regulation limits to PWOK asserted at turn on.	100	500	mSec
T_{PWOK_OFF} (below 75% load)	Delay from PWOK de-asserted to output voltages dropping out of regulation limits.	3	--	mSec
T_{PWOK_OFF} (above 75% load)	Delay from PWOK de-asserted to output voltages dropping out of regulation limits.	1	--	mSec
T_{PWOK_LOW}	Duration of PWOK being in the de-asserted state during an off/on cycle using AC or the PSON signal.	100	--	mSec
T_{VSB_12VOUT}	Delay from V _{SB} being in regulation to 12V _{OUT} output voltage being in regulation at AC turn on.	50	1000	mSec
T_{VSB_HOLDUP}	Time the V _{SB} standby voltage stays within regulation after loss of AC.	70	--	mSec
T_{AC_Fail_delay}	Delay from loss of AC to AC_Fail.		5	mSec

Note

1: The item “T_{PSON_OFF_DELAY}” measured without cap load.

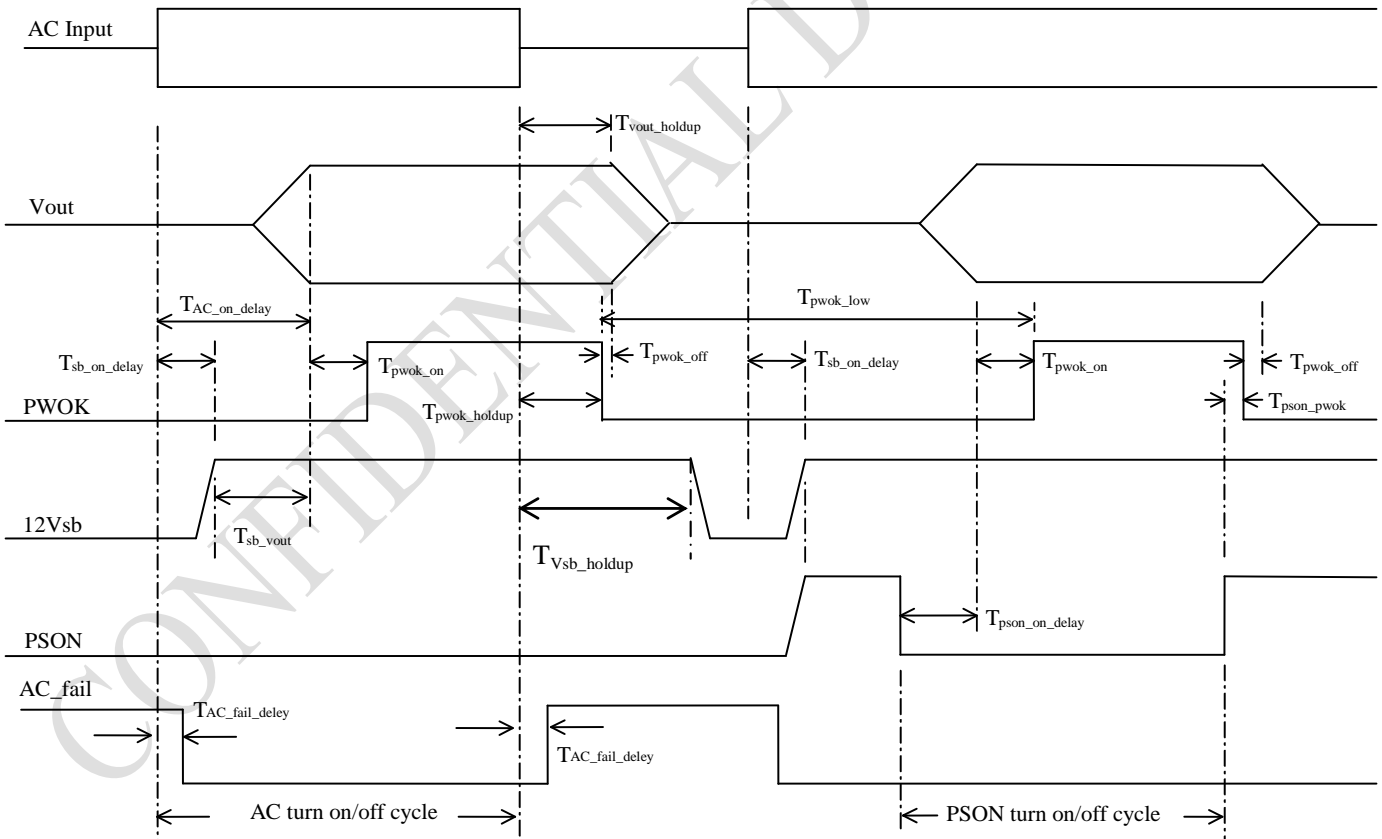

7 Additional Requirements

7.1 OTP

The power supply shall incorporate a thermal shutdown feature that turns off all outputs (except Standby output) When an over temperature condition occurs, the power supply will not be damaged and will automatically restart when the over temp condition no longer exists. Hysteresis shall be employed to prevent a frequent toggling on and off of the outputs.

The location of the OTP sensor should be on the component(s) most likely to overheat in the event of an abnormal ambient temperature or a blockage of airflow.

In normal operation, the OTP cannot activate when the power supply is operated in any of the specified operating conditions of sections 3.1, 4.1, and 9.1.

7.2 FAN FAIL

The fan(s) are running or the supply is in Standby mode. If there is a fan fault per section 6.12, the PSU is off and the PWOK must be low for at least 1mS before the main outputs go out of regulation, also the standby shall be protection itself due to thermal concern. When the fan fault is removed, the power supply shall recover automatically.

8 PMBus

8.1 PMBus requirement

8.1.1 Accuracy for V_{IN} , I_{IN} , P_{IN} , $12V_{OUT}$, I_{OUT} , P_{OUT}

Required Accuracy

	10% - 20% Load	> 20% - 50% Load	> 50% - 100% Load
P_{IN} / E_{IN}	+/- 5% or +/- 10W	+/- 5%	+/- 5%
V_{IN}	+/- 5%	+/- 5%	+/- 5%
I_{IN}	+/-5% or +/-0.05A	+/-5%	+/- 5%
FAN	+/- 500 rpm		
$12V_{OUT}$	+/- 5%	+/- 5%	+/- 5%
I_{OUT}	+/- 10%	+/- 5%	+/- 5%
P_{OUT}	+/- 5%	+/- 5%	+/- 5%
Temperature	+/- 3°C		

Note: At nominal input voltage measurement.

8.1.2 Smart Redundancy

Redundant power supplies in a system shall power ON or OFF depending upon loading state. Power supply ON or OFF (in the Smart Standby state) shall power on quickly to maintain full redundancy in the system. PSU in Cold Standby state should keep a low consumption $P_{in} < 5W$ (not included V_{SB} load), the measurement procedure and setting shall refer to 80 plus protocol.

8.1.3 Black Box

The power supply shall save the latest PMBus data and other pertinent data into nonvolatile memory when a critical event shuts down the power supply. This data shall be accessible via the SMBus interface with an external source providing power to the V_{SB} output.

8.1.4 System on-Line Bootloader

The power supply shall have the capability to update its firmware via the PMBus interface while it is in standby mode. This FW can be updated when in the system and in standby mode and outside the system with power applied to the V_{SB} pins.

9 Environmental Requirements

9.1 Temperature

9.1.1 Normal Operating Ambient (At Sea Level)

Minimum: + 0 °C

Maximum: + 55 °C

Maximum rate of change is 10 °C /hr.

The PSU allows a power de-rating operating once the operating temperature is 5°C over specified temperature and the acceptable output load is 70% of output load.

The thermal performance is designed without any shield on air inlet, system shall offer minimum CFM 11.19 (ft³/min) for PSU, if both conditions cannot be implemented, please offer the actually environment to Acbel for further evaluation.

9.1.2 Non-Operating Ambient (At Sea Level)

Minimum: - 40 °C

Maximum: + 70 °C

Maximum rate of change is 20 °C /hr.

9.2 Humidity

9.2.1 Operating

5 to 85% relative humidity. (Non-Condensing)

9.2.2 Non-Operating

Up to 95% relative humidity. (Non-Condensing)

9.3 Altitude

9.3.1 Operating

- 50 to 10,000 feet (3,048 meters). 5,000 meter is preferred.

NOTE:

1. The system ambient supports 55 °C at 950 m (3,000 feet) Altitude.
2. Maximum operating temperature is derated 1 °C per 125 m above 950 m.

9.3.2 Non-Operating

-50 to 50,000 feet (15,240 meters)

9.4 Thermal shock (none-operating)

Minimum -40 °C to Maximum +70 °C, transition time not to exceed 5 minutes. Duration of exposure to temperature extremes will be 20 minutes

9.5 Acoustic

No abnormal audible noise is allowed to be generated by the PSU. The PSU is designed to fulfill the thermal system and PSU requirements with the lowest possible fan speed, the fan speed shall be smoothly increase with ambient and load. The sound level shall be within following table.

Test condition :

Temperature : 22°C

Humidity : 50%

DISTANCE : 100 CM

Load	AMB.(C)	dB
20% Load	25	<60
	35	<60
50% Load	25	<60
	35	<65
100% Load	25	<75
	35	<75

9.6 Mechanical Shock and Random Vibration

Mechanical Shock:

Non-operating: 50 G Trapezoidal Wave, Velocity change = 170 in. / sec.

Three drops in each of six directions are applied to each of the samples.

Random Vibration

Non-operating.

Sine sweep:

5Hz to 500Hz @ 0.5gRMS at 0.5 octave/min; dwell 15 min at each of 3 resonant points;

Random profile:

5Hz @ 0.01g²/Hz to 20Hz @ 0.02g²/Hz (slope up); 20Hz to 500Hz @ 0.02g²/Hz (flat);

Input acceleration = 3.13gRMS; 10 min. per axis for 3 axis on all samples

10 Reliability

10.1 Reliability

The reliability requirements are based on the following product usage/application conditions.

AC Input Voltage Range	Refer to Section 3.1
DC Output Load	100% Maximum of rate output load
Temperature Range	Refer to Section 9.1
Relative Humidity	44% ±10% Non-condensing
Altitude	Sea Level
CMTBF	250K Hours @ 100% Load and 55 °C
Minimum Operating Life	5 Years @ 80% Load and 50 °C

10.2 E-Cap. Life

All used electrolytic caps must have a usefully life time which exceeds 43,800Hours at 80% load and normal input and 50°C power supply ambient temperature.



ACBEL POLYTECH INC.

10.3 Component De-rating



ACBEL POLYTECH INC.
康舒科技股份有限公司

159, Sec. 3, Tam-King Rd., Tamsui,
Taipei, Taiwan, 251 R.O.C.
Tel : (02)2623-7904~10 • 2621-7672~9
Sales DID : (02)2623-2750 • 2622-4300
Fax : ☐886-2-2623-6530 • 2623-4156

The component de-rating is designed to satisfy the latest revision of Acbel component design guideline, the document number is ELQZ-505-51. The key component de-rating is shown below:

Device Type	Parameter		Stress Factor	Device Type	Parameter		Stress Factor
Power Rectifiers	Reverse Voltage	V_R	80%	Aluminum Electrolytic	Voltage (Bulk Cap)	V_{max}	95%
	Forward Current	I_{Fmax}	80%		Ripple Current	I_{rated}	95%
	Junction Temp.	T_J	80%		Solid Electrolytic (Oscon)	Voltage (Others)	V_{max}
Schottky Diode	Reverse Voltage	V_R	95%	Temperature		T_{max}	90%
	Forward Current	I_{Fmax}	90%	Mag. Device Toroid		Flux density	B
	Junction Temp.	T_J	80%	Mag. Device Ferrite	Flux density	B	70%
FET	Breakdown Voltage (>400V)	V_{DSS}	95%				
	Drain Current	I_D	80%				
	Junction Temp.	T_J	80%				

11 EMC and Safety Requirements

The power supply must comply with all regulatory requirements for its intended geographical market. Depending on the chosen market, regulatory requirements may vary. Although a power supply can be designed for worldwide compliance, there may be cost factors that drive different versions of supplies for different geographically targeted markets. The power supply meets below standard, and the mark.

11.1 Safety Mark and Standards

UL/cUL, TUV, CB, CE, CCC, BSMI.

11.2 EMI Requirement

The power supply meet EMI standard as below, need margin 6dB

EN55022 Class A.

CISPR22 Class A.

FCC Class A.

11.3 Hi-pot

The power supply unit must pass a 2550 V_{DC} Residual Voltage test between primary to chassis ground. All production units must pass a 2550 Vdc Hi-Pot test between primary to chassis ground or follow safety agency requirement. The voltage must be ramped up to 2550 within 2.0S and it must be maintained at that level for a minimum of 1 sec. without failure, arc and breakdown or it must comply with safety requirement.

Test voltage	DC
Specify test voltage of Vdc	2550VDC
Current Sensitivity or Current Trip Setting	100uAdc
Ramp-Up Time	2S
Dwell time	1S
RAMP-HI	OFF
Arc fail	ON
Arc sense	5

11.4 Ground Continuity

All production units must pass a ground continuity test with less than 0.1 ohm from the safety ground (third wire) input pin to the power supply chassis. Each unit must be marked to indicate it passed the test.



ACBEL POLYTECH INC.



ACBEL POLYTECH INC.
康舒科技股份有限公司

159, Sec. 3, Tam-King Rd., Tamsui,
Taipei, Taiwan, 251 R.O.C.
Tel : (02)2623-7904~10 • 2621-7672~9
Sales DID : (02)2623-2750 • 2622-4300
Fax : ☐886-2-2623-6530 • 2623-4156

12 Mechanical Drawing

AIR FLOW DIRECTION

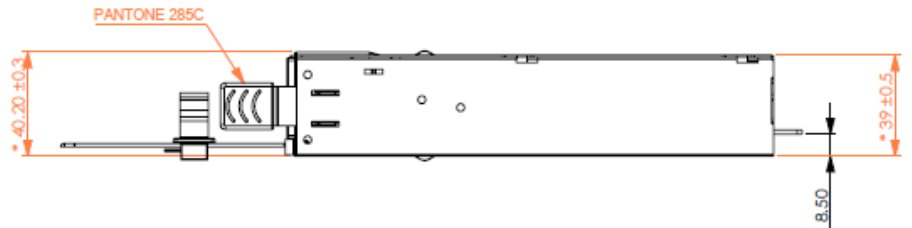
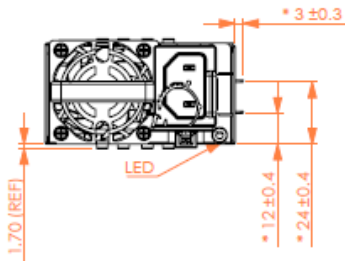
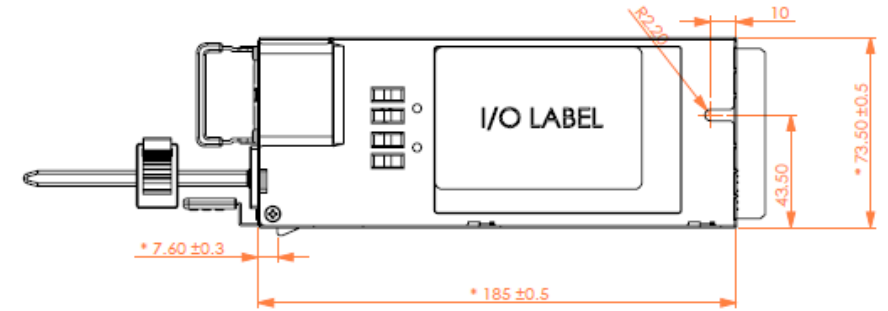

End of document.

CONFIDENTIAL